

# Accessories for SCM5B Analog Modules

## FEATURES

- 1-, 2-, 8-, 16-POSITION BACKPANELS
- 19-INCH MOUNTING RACK FOR BACKPANELS
- MULTIPLEXED AND NON-MULTIPLEXED BACKPANELS
- INTERFACE CABLES
- MODULE EVALUATION BOARD
- CABLE-TO-SCREW-TERMINAL INTERFACE BOARD



## SCMPB01 16-POSITION ANALOG I/O BACKPANEL, NON-MULTIPLEXED

## DESCRIPTION

The SCMPB01 16-channel backpanel (Figure 1) can accept any of the SCM5B analog modules in any mixture. It can be mounted on the SCMXRK-002 19-inch metal rack. The SCMPB01 has 16 non-addressable analog I/O signal channels which provides each module with its own analog bus. The module output switch is continuously "on" when using this backpanel and all sixteen module outputs are simultaneously accessible to high-speed data acquisition (ADC) boards. A set of inter-channel bridge jumpers permits connecting an input module's output to an output module's input, providing two levels of isolation. A temperature sensor is mounted on each channel to provide cold junction compensation for thermocouple input modules (See Figure 2 for schematic). Field connections are terminated with four screw

terminals at each module site. Use system interface cable SCMXCA004-XX for connection to the host system.

## SPECIFICATIONS

Operating Temperature:	-40°C to +85°C 95% relative humidity, non-condensing
Interface Connector:	High Density Screw Clamp, 14 AWG Max 26-pin, male header connector

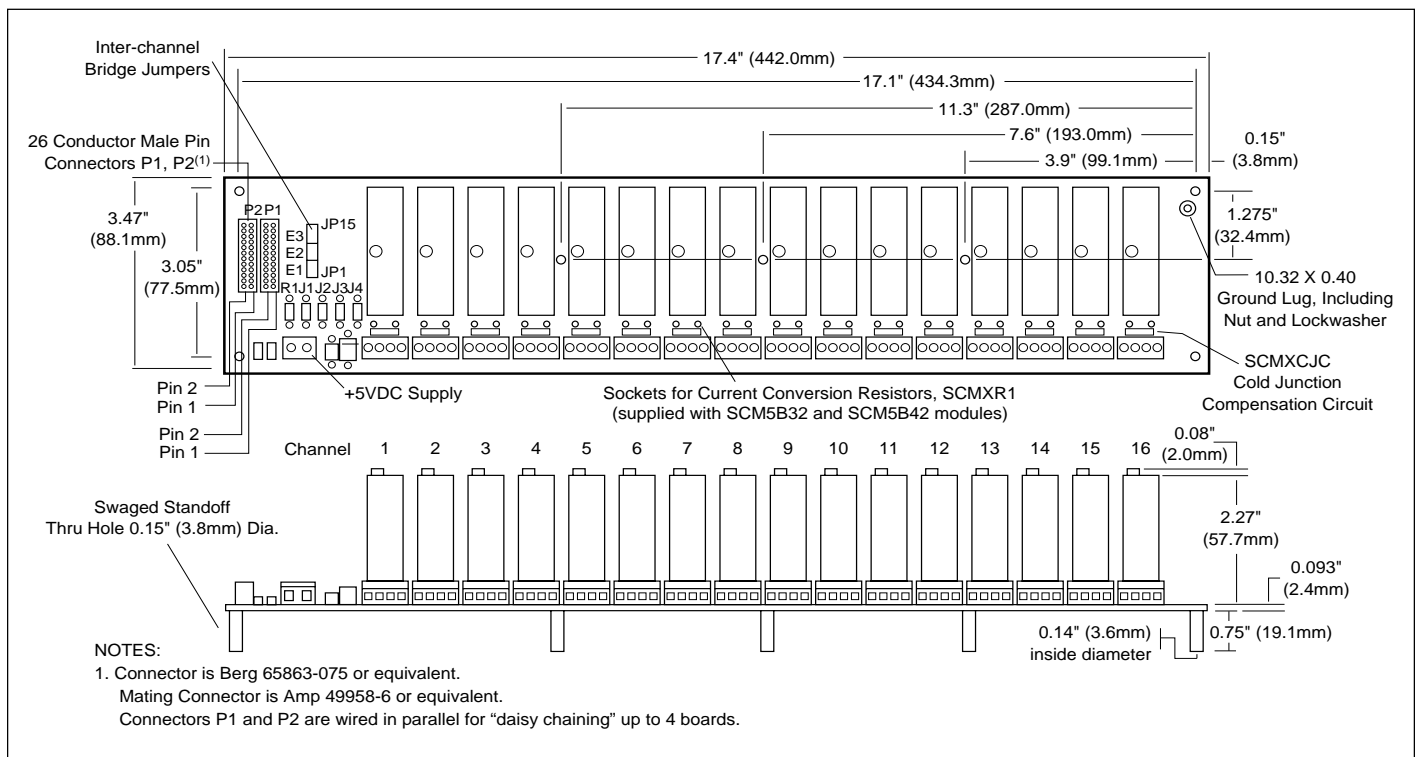
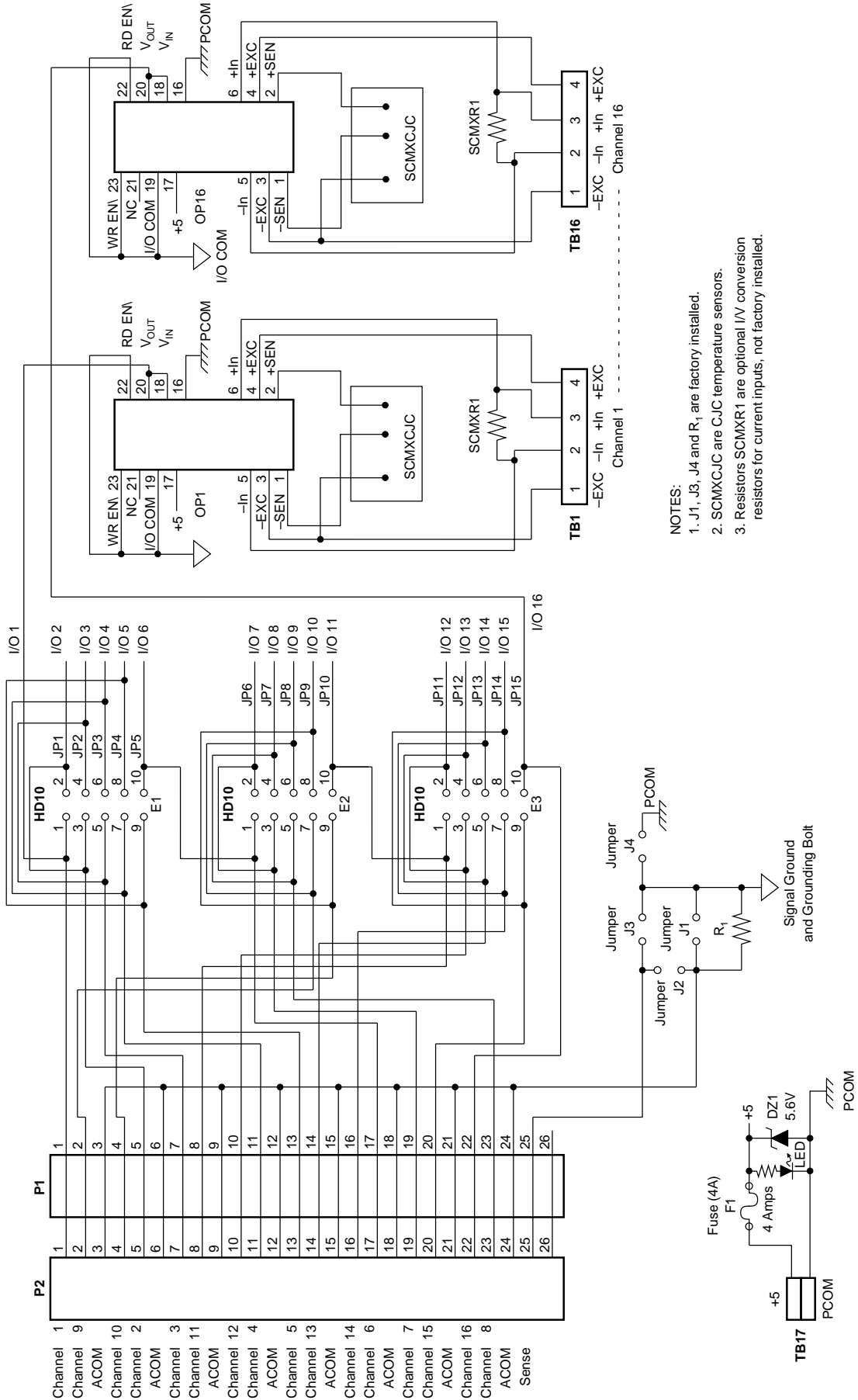

FIGURE 1. SCMPB01 Analog I/O Backpanel.



- NOTES:
1. J1, J3, J4 and R<sub>1</sub> are factory installed.
  2. SCMXCJC are CJC temperature sensors.
  3. Resistors SCMXR1 are optional I/V conversion resistors for current inputs, not factory installed.

FIGURE 2. SCMPB01 Schematic.

## ELECTRICAL

### P1 AND P2 CONNECTOR

Connection to the host system is made at connectors P1 and P2. These connectors are electrically equivalent. Two connectors are provided to allow both analog input and analog output from host systems having individual input and output connectors.

### ADJACENT CHANNEL JUMPERS

Adjacent channels may be connected together to provide an isolated output signal from an isolated input module, providing two levels of 1500V isolation. This capability is provided with the 15 jumpers labeled JP1 through JP15 on headers E1, E2, and E3. A simplified drawing of the SCMPB01 schematic for Channel 1 through 4 is shown in Figure 3.

Example: Assume an SCM5B30 input module is installed in Channel 1 position and an SCM5B39 output module is installed in Channel 2 position. If JP1 is installed, the output of Channel 1 is connected to the input of Channel 2, which provides two levels of 1500V isolation.

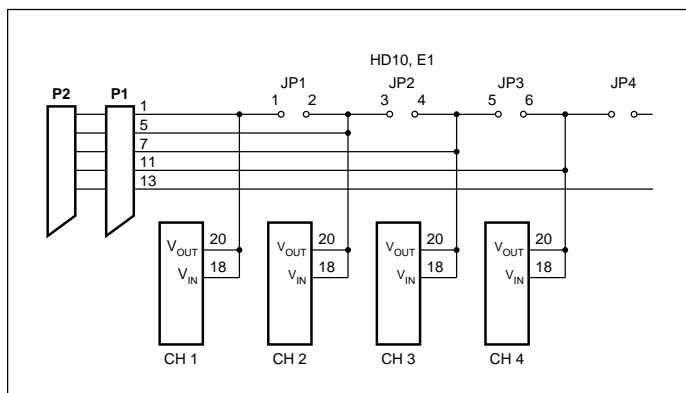

FIGURE 3. SCMPB01 Adjacent Channel Jumpers.

### POWER

The SCMPB01 backpanel requires external +5VDC  $\pm 5\%$  power. The chassis mounted SCMXPRE-003 or SCMXPR-003 power supplies have adequate capacity to power any combination of modules.

### FUSING

The SCMPB01 backpanel power is fuse protected through F1. This is a Littlefuse type 252004, 4 amp fuse. Zener diode DZ1 provides extra protection by clamping the input power voltage to +5.6V. If the input supply voltage connection is reversed, this zener diode will be forward biased and fuse F1 will be blown.

## ORDERING INFORMATION

Part Number	Description
SCMPB01	Standard 16-channel backpanel.
SCMPB01-1	SCMPB01 without cold junction compensation circuits. Use when cost savings is desired and thermocouple input modules SCM5B37 and SCM5B47 will not be used.
SCMPB01-2	SCMPB01 with DIN Rail mounting option. The backpanel is mounted on a piece of anodized aluminum, which is captured by the SCMXBEFE DIN Rail mounting elements. The backpanel is shipped fully assembled.
SCMPB01-3	SCMPB01-1 with Din Rail mounting option. See SCMPB01 and SCMPB01-2 for details.

### GROUNDING

Figure 4 details the optional ground jumper configuration available on the SCMPB01 backpanel. Jumpers J1, J3, and J4 are factory installed.

Jumper J1 connects the AGND shield wires (pins 3, 6, 9, 12, 15, 18, 21, and 24) to the backpanel signal ground. This provides a ground connection between the host system and backpanel. Jumper J1 is required if output modules (SCM5B39, SCM5B49) are used, or if there is no high impedance sense input (input low of a differential or pseudo-differential system) on the host measurement system.

Jumper J3 connects the SENSE line (pin 25) to the backpanel signal ground. If the host system has the capability, this allows measuring the SCMPB01 ground potential.

For proper operation of the output switch or track-and-hold circuit when using the SCMPB01/05 backpanels, a current path must exist between the host control logic power common and module I/O Common (module pin 19). This path can be established on the SCMPB01 via jumper J4. If this connection exists elsewhere in the system, jumper J4 should be removed since possible ground loops could exist. Other connections of power ground

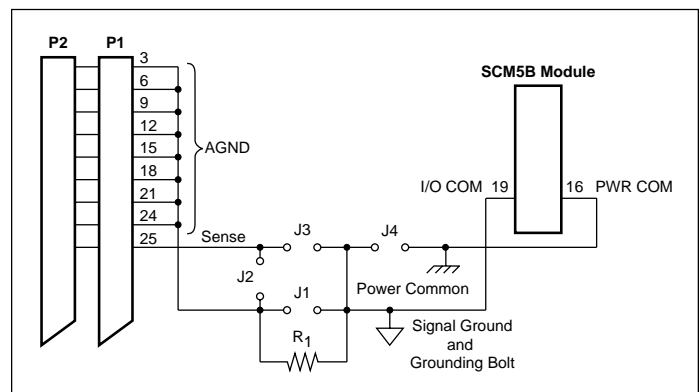

FIGURE 4. SCMPB01 Grounding Diagram.

and signal ground usually occur at the A/D or D/A converter of the host measurement system. More information on grounding can be found in Application Note AN502.

If the connection of power common and AGND shield wires exist in the host measurement system, an optional resistive connection between AGND and the backpanel signal ground can be made via  $R_1$ .  $R_1$  can be as large as 10K ohms; 100 ohms is a recommended value. Jumper J2 can be used to connect the SENSE line to  $R_1$  when this ground configuration is used.

For full protection against large electrical disturbances on the field-side of the SCM5B modules, a #10-32 ground stud is provided on the backpanel. An electrical connection between this ground stud and system ground should be provided with a large gauge wire of the shortest possible length. When this connection is made, a possible ground loop could result through the AGND shield wires and backpanel signal ground. If the application involves only input modules and a differential input is used by the host measurement system, J1 should be removed. Remember that J1 is required if output modules are used or if the host system does not have differential inputs.



# SCMPB02 16-POSITION ANALOG I/O BACKPANEL, MULTIPLEXED

## DESCRIPTION

The SCMPB02 16-channel backpanel (Figure 5) can accept any of the SCM5B analog modules in any mixture. It can be mounted on the SCM5B-002 19-inch metal rack. The SCMPB02 has two analog buses; one for analog input and one for analog output. This two-bus configuration takes advantage of the switch controlled outputs on the input modules and the track-and-hold inputs on the output modules. A temperature sensor is mounted on each channel to provide cold junction compensation for thermocouple input modules (See Figure 6 for schematic). Field connections are terminated with four screw terminals at each module site. Up to four SCMPB02 backpanels may be daisy-chained. Use SCM5B005 cable for daisy chaining and SCM5B004-XX cable for connecting to host computer.

## SPECIFICATIONS

Operating Temperature:	-40°C to +85°C 95% relative humidity, non-condensing
Interface Connector: Field System	High Density Screw Clamp, 14 AWG Max 26-pin, male header connector
Address Input Logic Levels: Max Logic "0" Min Logic "1"	0.8V 2.0V

I <sub>I</sub> Input Current, "0" or "1"	0.1µA max at 25°C 1.0µA max -25°C to +85°C
RD EN <sub>I</sub> or WR EN <sub>I</sub> Signal Delay from Connector P1 to Channels 1-16 Standalone (address 0-15)  Expanded (address 16-63)	51ns at 25°C 64ns at -25°C to +85°C 100ns at 25°C 126ns at -25°C to +85°C

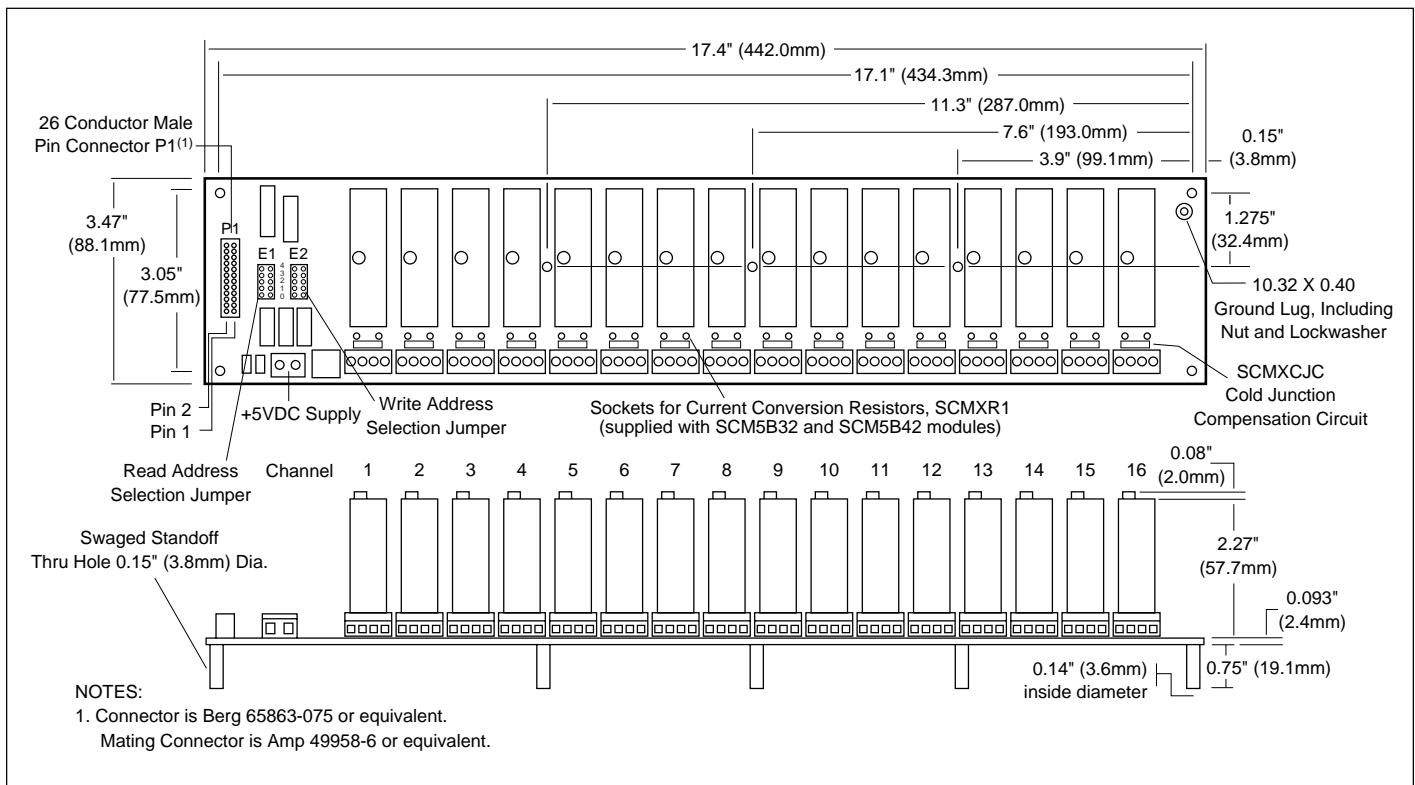

FIGURE 5. SCMPB02 Analog I/O Backpanel.

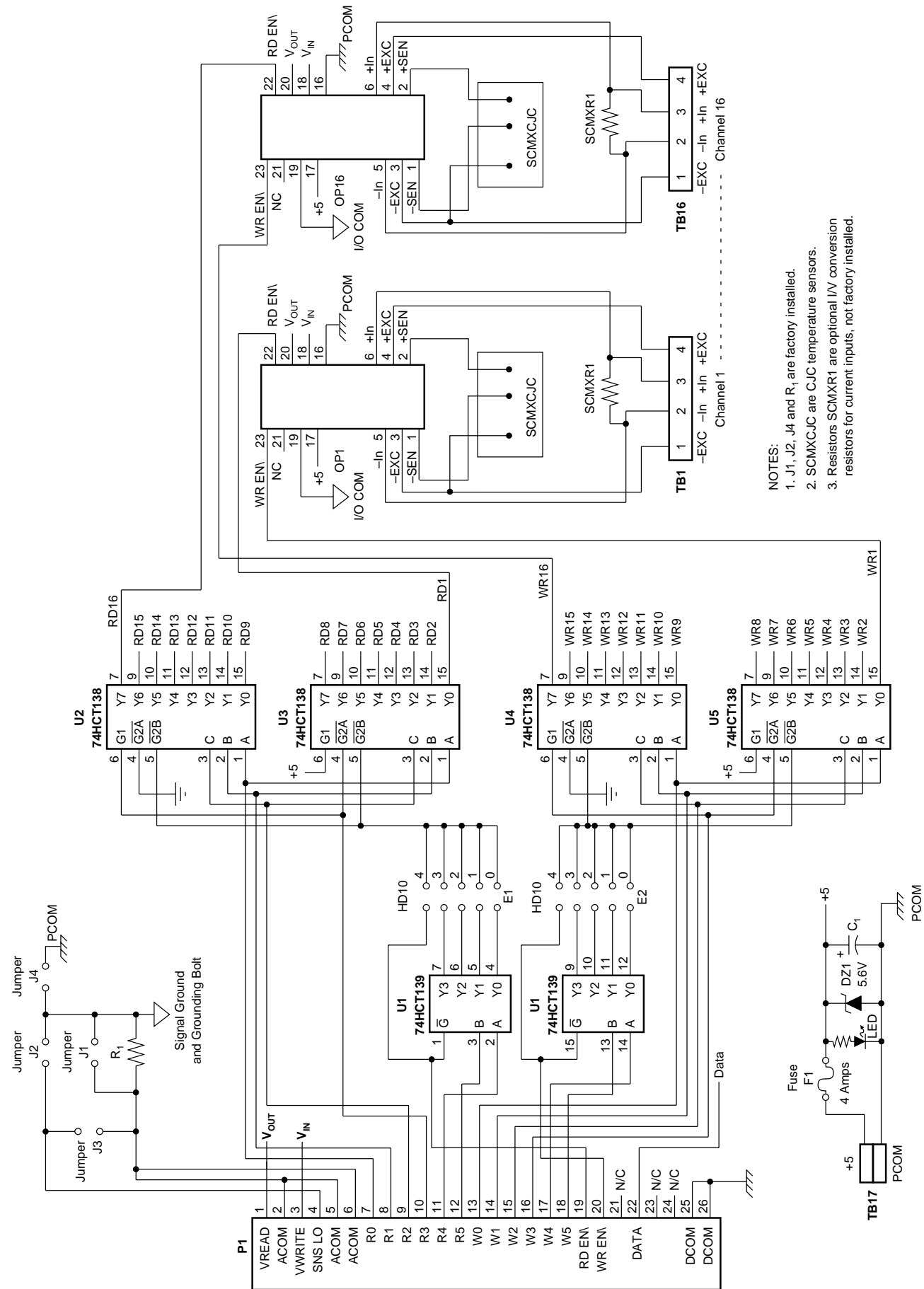

FIGURE 6. SCMPB02 Schematic.

- NOTES:
1. J1, J2, J4 and R<sub>1</sub> are factory installed.
  2. SCMXCJC are C-JC temperature sensors.
  3. Resistors SCMXR1 are optional I/V conversion resistors for current inputs, not factory installed.

# ELECTRICAL

## P1 CONNECTOR

The 26 pin P1 connector provides the signal interface between the SCMPB02 backpanel and the host measurement system. Two separate analog bus connections are provided; one for analog input signals and one for analog output signals. Two sets of six address lines and an enable pin allow input and output modules to be independently multiplexed onto their respective analog signal bus. R0 thru R5 and RDNAB are used for input modules, and W0 thru W5 and WRENAB are used for output modules.

## ADDRESS SELECTION

The SCMPB02 backpanel has address decoding circuitry to allow multiplexing any combination of up to 16 input or output modules. Capability is also provided in the address decode circuitry to expand the system to 64 channels (four SCMPB02 backpanels) of multiplexed input or output. Jumpers on HD10 header, E1 and E2 group, select which set of 16 addresses are assigned to a particular backpanel. The E1 group assigns a set of 16 addresses for input modules, and the E2 group assigns a set of 16 addresses for output modules. The table below shows the correlation of jumper position to address range.

E1 Jumper Pos	E2 Jumper Pos	Address Range/Mode
4	4	0-15, STAND ALONE
3	3	48-63, EXPANDED
2	2	32-47, EXPANDED
1	1	16-31, EXPANDED
0	0	0-15, EXPANDED

To connect multiple SCMPB02 backpanels in this expanded configuration, use interconnect cable SCMXCA005.

## POWER

The SCMPB02 backpanel requires external +5VDC  $\pm 5\%$  power. The chassis mounted SCMXPRE-003 or SCMXPR-003 power supplies have adequate capacity to power any combination of modules.

## FUSING

The SCMPB02 backpanel power is fuse protected through F1. This is a Littelfuse type 252004, 4 amp fuse. Zener diode DZ1 provides extra protection by clamping the input power voltage to +5.6V. If the input supply voltage connection is reversed, this zener diode will be forward biased and fuse F1 will be blown.

## ORDERING INFORMATION

Part Number	Description
SCMPB02	Standard 16-channel backpanel.
SCMPB02-1	SCMPB02 without cold junction compensation circuits. Use when cost savings is desired and thermocouple input modules SCM5B37 and SCM5B47 will not be used.
SCMPB02-2	SCMPB02 with DIN Rail mounting option. The backpanel is mounted on a piece of anodized aluminum, which is captured by the SCMXBEFE DIN Rail mounting elements. The backpanel is shipped fully assembled.
SCMPB02-3	SCMPB02-1 with Din Rail mounting option. See SCMPB02 and SCMPB02-2 for details.

## GROUNDING

Figure 7 below details the optional ground jumper configuration available on the SCMPB02 backpanel. Jumpers J1, J2, and J4 are factory installed.

Jumper J1 connects the SIG COM shield wires (pins 2, 5, and 6) to the backpanel signal ground. This provides a ground connection between the host system and backpanel. Jumper J1 is required if output modules (SCM5B39, SCM5B49) are used, or if there is no high impedance sense input (input low of a differential or pseudo-differential system) on the host measurement system.

Jumper J2 connects the SNS LO line (pin 4) to the backpanel signal ground. If the host system has the capability, this allows measuring the SCMPB02 ground potential.

For proper operation of the output switch or track-and-hold circuit when using the SCMPB02/06 backpanels, a current path must exist between the host control logic power common and module I/O Common (module pin 19). This path can be established on the SCMPB02 via jumper J4. If this connection exists elsewhere in the system, jumper J4 should be removed since possible ground loops could exist. Other connections of power ground and signal ground usually occur at the A/D or D/A converter of the host measurement system. More information on grounding can be found in Application Note AN502.

If the connection of power common and SIG COM shield wires exist in the host measurement system, a resistive connection between SIG COM and the backpanel signal ground can be made via R<sub>1</sub>. R<sub>1</sub> can be as large as 10K ohms; 100 ohms is a recommended value. Jumper J3 can be used to connect the SNS LO line to R<sub>1</sub> when this ground configuration is used.

For full protection against large electrical disturbances on the field-side of the SCM5B modules, a #10-32 ground stud is provided on the backpanel. An electrical connection between this ground stud and system ground should be provided with a large gauge wire of the shortest possible length. When this connection is made, a possible ground loop could result through the SIG COM shield wires and backpanel signal ground. If the application involves only input modules and a differential input is used by the host measurement system, J1 should be removed. Remember that J1 is required if output modules are used or if the host system does not have differential inputs.

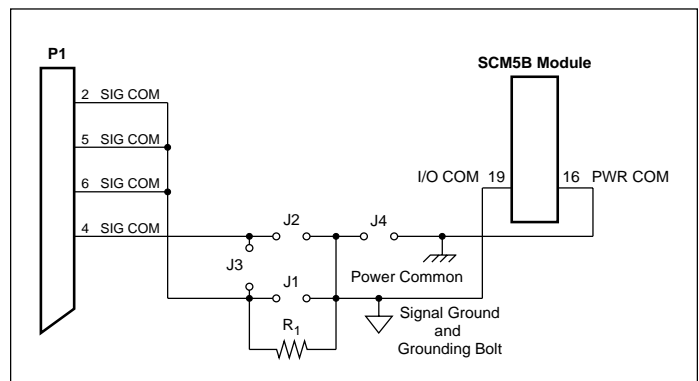

FIGURE 7. SCMPB02 Grounding Diagram.



# SCMPB03/SCMPB04 ONE/TWO POSITION ANALOG I/O BACKPANELS

## DESCRIPTION

The SCMPB03 is a single channel mounting panel for the SCM5B modules. The SCMPB04 is a dual channel mounting panel for the SCM5B modules. They are both DIN rail compatible.

See Figures 9, and 10 for wiring diagrams, Figure 11 for schematics.

The following accessories are required for mounting one SCMPB03/04 panel (Figure 8):

Qty	Model	Description
1	SCMXBEFE	Base element with snap foot
2	SCMXSE	Side element

The following accessories are required for mounting two or more SCMPB03/04 panels:

Qty	Model	Description
2	SCMXBEFE	Base element with snap foot
2	SCMXSE	Side element
(# panels)-2	SCMXBE	Base element without snap foot
(4 x (# panels))-4	SCMXVS	Connection pins

The following DIN rail styles are available. Specify length in meters (-XX)

SCMX RAIL 1-XX	EN 50022-35x7.5 (slotted steel)
SCMX RAIL 2-XX	EN 50035-G32 (slotted steel)
SCMX RAIL 3-XX	EN 50022-35x15 (slotted steel)

## SPECIFICATIONS

Operating Temperature:	-40°C to +85°C 95% relative humidity, non-condensing
Interface Connector:	High Density Screw Clamp, 14 AWG Max High Density Screw Clamp, 14 AWG Max

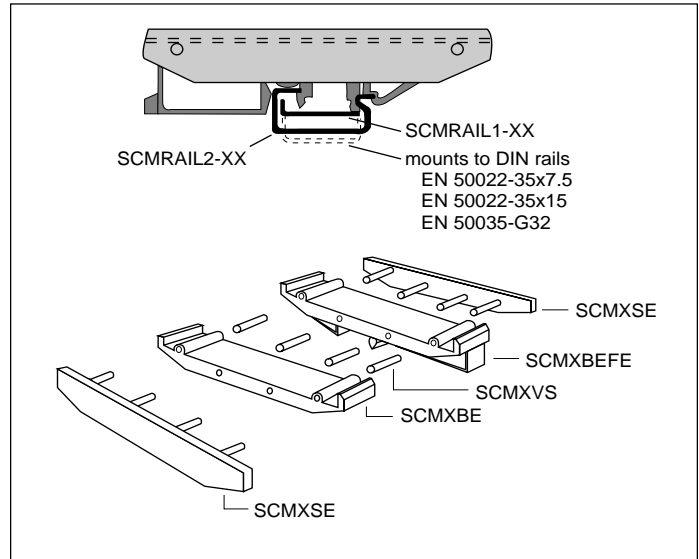

FIGURE 8. DIN Rail Mounting Elements.

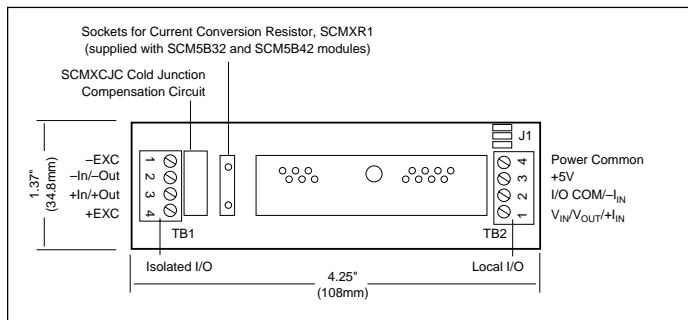

FIGURE 9. SCMPB03 Analog I/O Backpanel.

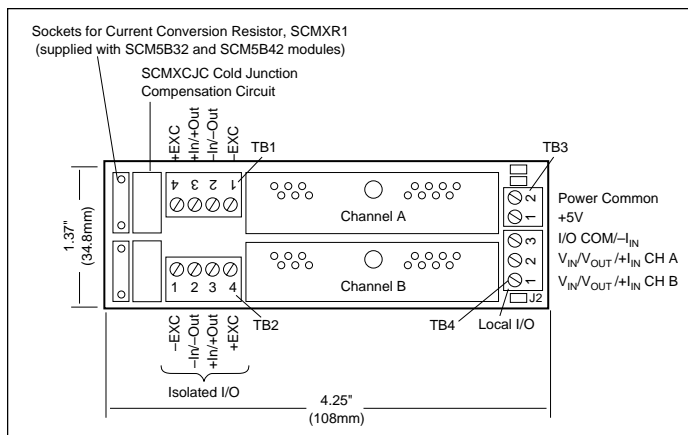

FIGURE 10. SCMPB04 Analog I/O Backpanel.

## ORDERING INFORMATION

Part Number	Description
SCMPB03	Standard single channel backpanel. No mounting hardware included.
SCMPB03-2	One SCMPB03 with DIN Rail mounting hardware. Shipped fully assembled. Accepts one SCM5Bxx-xx module.
SCMPB04	Standard dual channel backpanel. No mounting hardware included.
SCMPB04-1	SCMPB04 without cold junction compensation circuits. Use when cost savings is desired and thermocouple input modules SCM5B37 and SCMPB47 will not be used.
SCMPB04-2	One SCMPB04 with DIN Rail mounting hardware. Shipped fully assembled. Accepts 2 SCM5Bxx-xx modules.
SCMPB04-3	SCMPB04-1 with DIN Rail mounting option. See SCMPB04 and SCMPB04-2 for details.

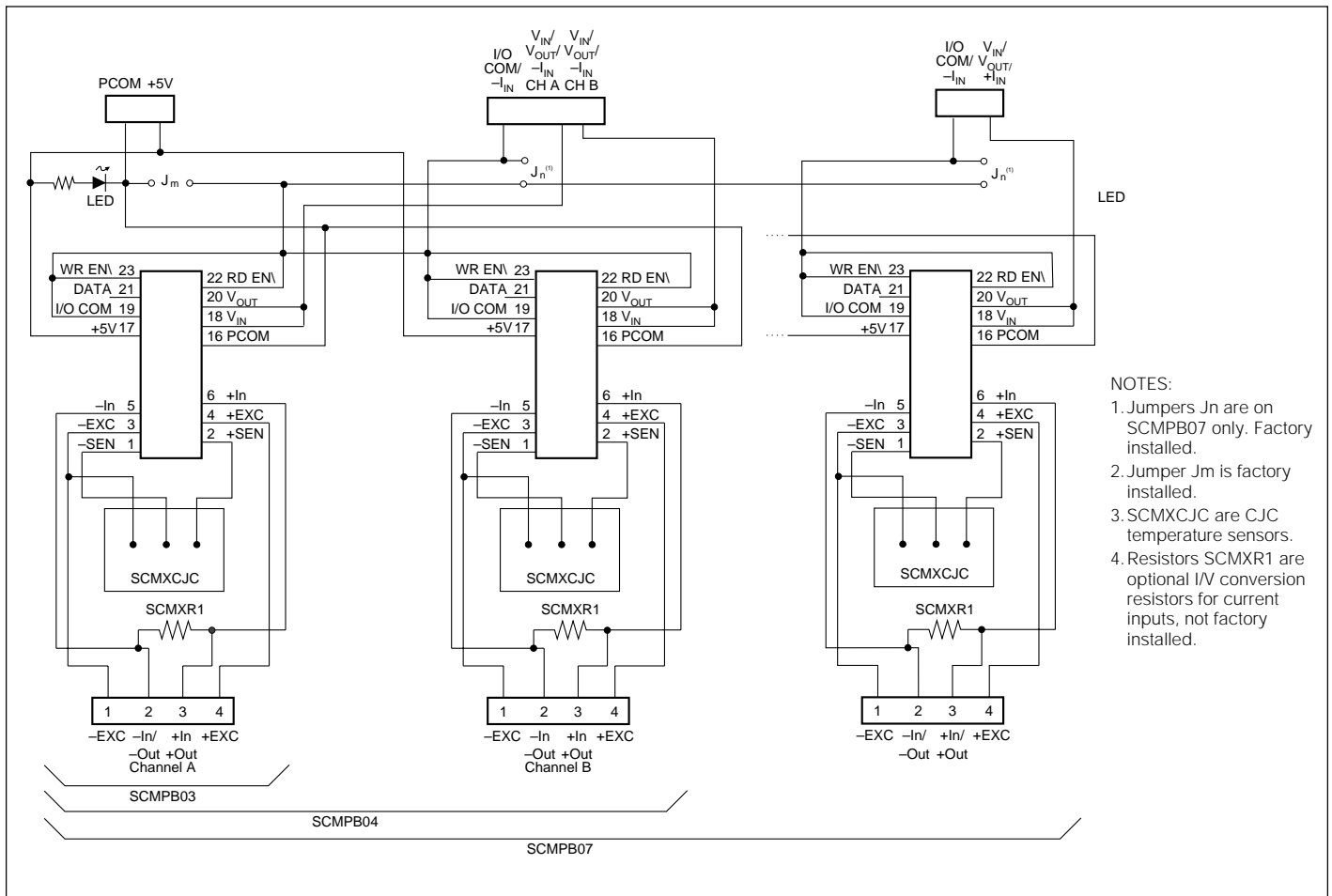

FIGURE 11. SCMPB03/SCMPB04/SCMPB07 Schematic.



# SCMPB05 8-POSITION ANALOG I/O BACKPANEL, NON-MULTIPLEXED

## DESCRIPTION

The SCMPB05 analog module mounting board has a capacity of eight analog input and/or output modules in any combination. It can be mounted on the SCM XRK-002 19-inch metal rack. A separate analog signal path is provided for each channel and each channel's signal is accessible at redundant 26-pin connectors. The module output switch is continuously "on" when using this backpanel and all eight module outputs are simultaneously accessible to high-speed data acquisition (ADC) boards.

On-board jumpers permit paralleling two SCMPB05 boards to form a SCMPB01 equivalent. An additional set of inter-channel bridge jumpers permits connecting an input module's output to an output module's input, providing two levels of isolation (Figures 12, 13).

Jumpers on the SCMPB05 permit user selection of low (i.e. channels 0-7) or high (i.e. channels 8-15) addresses.

A temperature sensor is mounted on each channel to provide cold junction compensation for thermocouple input modules (See Figure 13 for Schematic ). Field connections are terminated with four screw terminals at each module site. Use system interface cable SCM XCA004-XX for connection to the host system.

## SPECIFICATIONS

Operating Temperature:	-40°C to +85°C 95% relative humidity, non-condensing
Interface Connector:	High Density Screw Clamp, 14 AWG Max 26-pin, male header connector

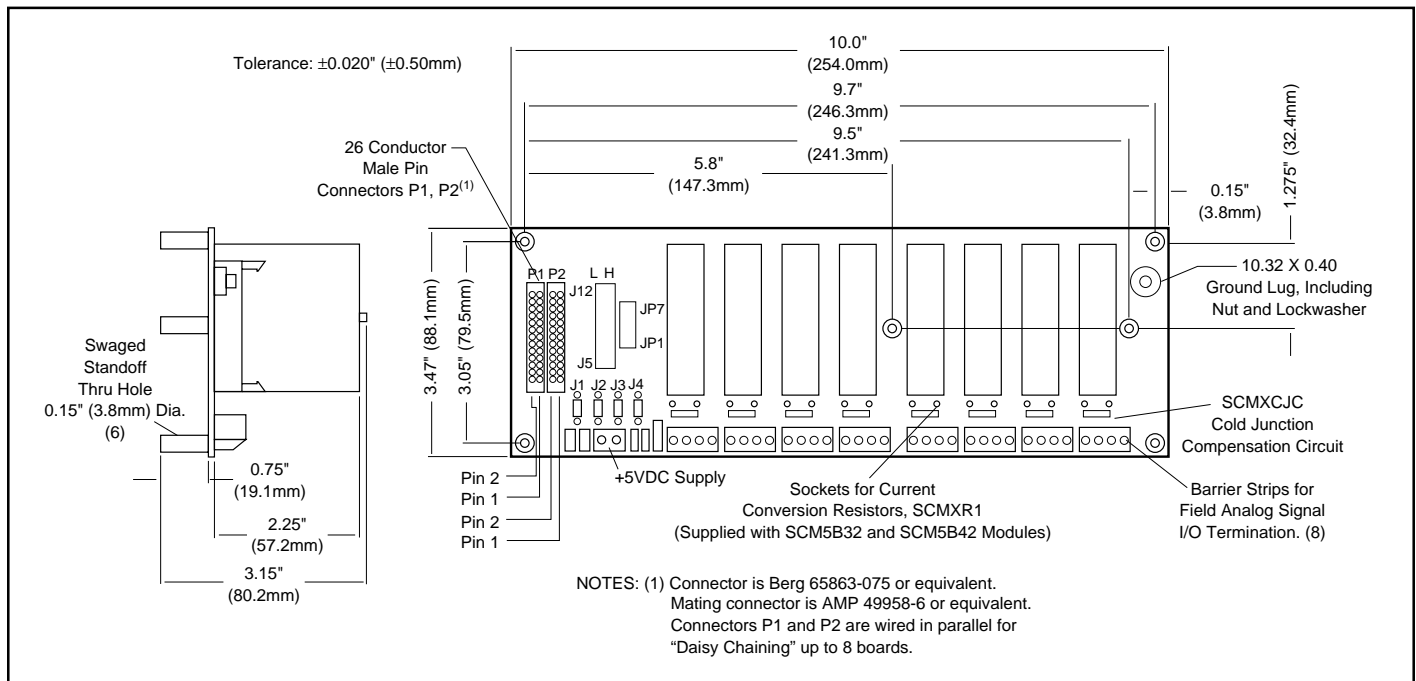

FIGURE 12. SCMPB05 Analog I/O Backpanel.

## ELECTRICAL

### ADDRESS SELECTION

Module addresses may be selected as low (channels 0-7) or high (channels 8-15) using the sets of 3 pins labeled J5 through J12. Place a jumper over the two pins closest to the ribbon cable connectors, P1 and P2, to select a low address (factory configuration) or over the two pins furthest from the ribbon cable connectors, P1 and P2, to select a high address.

### ADJACENT CHANNEL JUMPERS

Adjacent channels may be connected together to provide an isolated output signal from an isolated input module, providing two levels of 1500V isolation. This capability is provided with the seven jumpers labeled JP1-JP7. See page 81 for an example.

Refer to page 81 for additional notes on the P1 and P2 connectors, power requirements, fusing and grounding issues.

## ORDERING INFORMATION

Part Number	Description
SCMPB05	Standard 8-channel backpanel.
SCMPB05-1	SCMPB05 without cold junction compensation circuits. Use when cost savings is desired and thermocouple input modules SCM5B37 and SCM5B47 will not be used.
SCMPB05-2	SCMPB05 with DIN Rail mounting option. The backpanel is mounted on a piece of anodized aluminum, which is captured by the SCMXBEFE DIN Rail mounting elements. The backpanel is shipped fully assembled.
SCMPB05-3	SCMPB05-1 with Din Rail mounting option. See SCMPB05 and SCMPB05-2 for details.

SCM5B

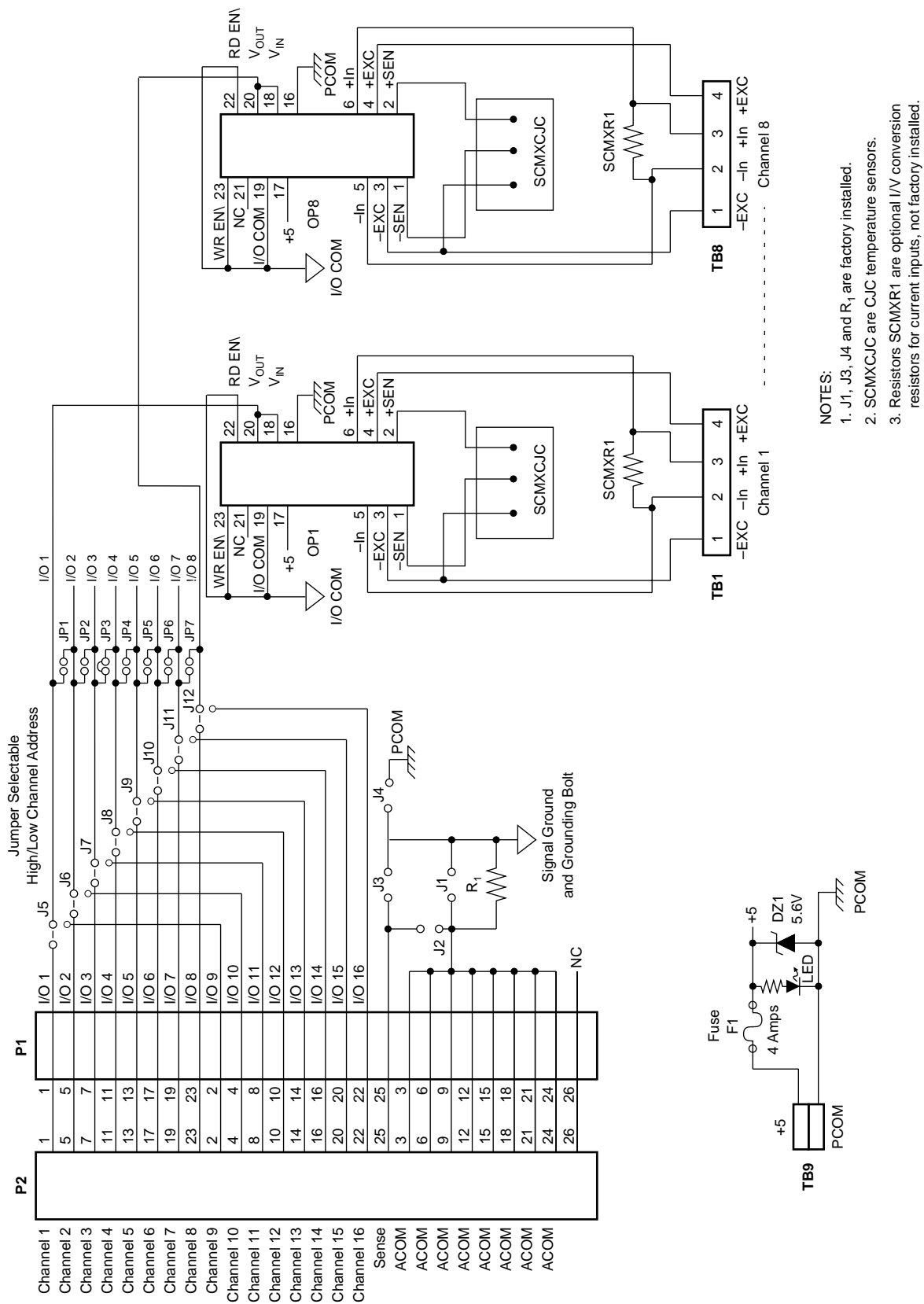

- NOTES:
1. J1, J3, J4 and R<sub>1</sub> are factory installed.
  2. SCMXCJC are CJC temperature sensors.
  3. Resistors SCMXR1 are optional I/V conversion resistors for current inputs, not factory installed.

FIGURE 13. SCMPB05 Schematic.



# SCMPB06 8-POSITION ANALOG I/O BACKPANEL, MULTIPLEXED

## DESCRIPTION

The SCMPB06 backpanel (Figure 14) can accept up to eight SCM5B modules in any combination. It can be mounted on the SCMXRK-002 19-inch metal rack. The SCMPB06 has two analog buses; one for analog input and one for analog output. This two-bus configuration takes advantage of the switch controlled outputs on the input modules and the track-and-hold inputs on the output modules. A temperature sensor is mounted on each channel to provide cold junction compensation for thermocouple input modules (See Figure 15 for schematic). Field connections are terminated with four screw terminals at each module site. Up to eight SCMPB06 backpanels may be daisy-chained. Use SCMCA005 cable for daisy chaining and SCMCA004-XX cable for connecting to host computer.

Jumpers on the SCMPB06 permit user selection of low (i.e. channels 0-7) or high (i.e. channels 8-15) addresses.

## SPECIFICATIONS

Operating Temperature:	-40°C to +85°C 95% relative humidity, non-condensing	
Interface Connector:	Field System High Density Screw Clamp, 14 AWG Max 26-pin, male header connector	
Address Input Logic Levels:	Max Logic "0" Min Logic "1"	0.8V 2.0V
I <sub>i</sub> Input Current, "0" or "1"	0.1µA max at 25°C 1.0µA max -25°C to +85°C	
RD EN\ or WR EN\ Signal Delay from Connector P1 to Channels 0-7	51ns at 25°C 64ns at -25°C to +85°C 100ns at 25°C 126ns at -25°C to +85°C	
Standalone (address 0-7)		
Expanded (address 8-63)		

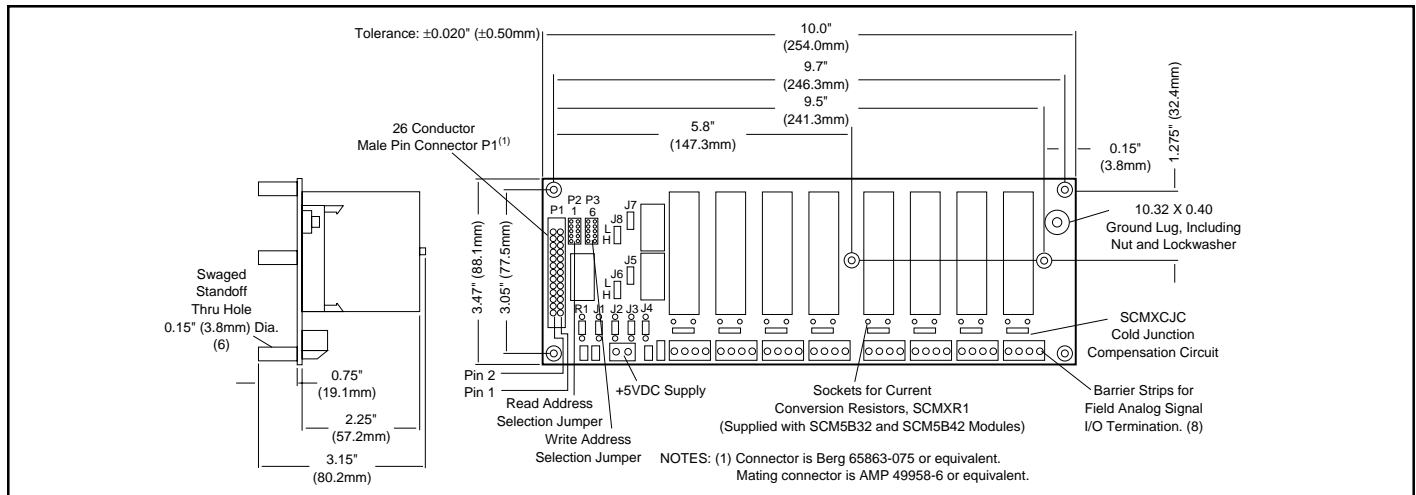

FIGURE 14. SCMPB06 Analog I/O Backpanel.

## ELECTRICAL

### ADDRESS SELECTION

Module read and write addresses may be selected as low (channels 0-7) or high (channels 8-15) using the four sets of 3 position jumpers labeled J5 through J8. Place a jumper over the two pins furthest from the field I/O termination blocks on all four sets to select a low address (factory configuration) or over the two pins closest to the field I/O termination blocks on all four sets to select a high address.

The SCMPB06 backpanel has address decoding circuitry to allow multiplexing any combination of up to 8 input or output modules. Capability is also provided in the address decode circuitry to expand the system to 64 channels (eight SCMPB06 backpanels) of multiplexed input or output. Jumpers select which set of 16 addresses are assigned to a particular backpanel. The Read

Address group assigns a set of 16 addresses for input modules, and the Write Address group assigns a set of 16 addresses for output modules. The table below shows the correlation of jumper position to address range. Refer to page 84 for additional notes on the P1 connector, power requirements, fusing, and grounding issues.

### Address Selection Jumpers

Read Address Jumper (P2)	Write Address Jumper (P3)	Address Range
1	6	0-15 Stand alone
2	7	48-63 Expanded
3	8	32-47 Expanded
4	9	16-31 Expanded
5	10	0-15 Expanded

## ORDERING INFORMATION

Part Number	Description
SCMPB06	Standard 8-channel backpanel.
SCMPB06-1	SCMPB06 without cold junction compensation circuits. Use when cost savings is desired and thermocouple input modules SCM5B37 and SCM5B47 will not be used.
SCMPB06-2	SCMPB06 with DIN Rail mounting option. The backpanel is mounted on a piece of anodized aluminum, which is captured by the SCMXBEFE DIN Rail mounting elements. The backpanel is shipped fully assembled.
SCMPB06-3	SCMPB06-1 with Din Rail mounting option. See SCMPB06 and SCMPB06-2 for details.

Call 800-444-7644  
For Information and Assistance



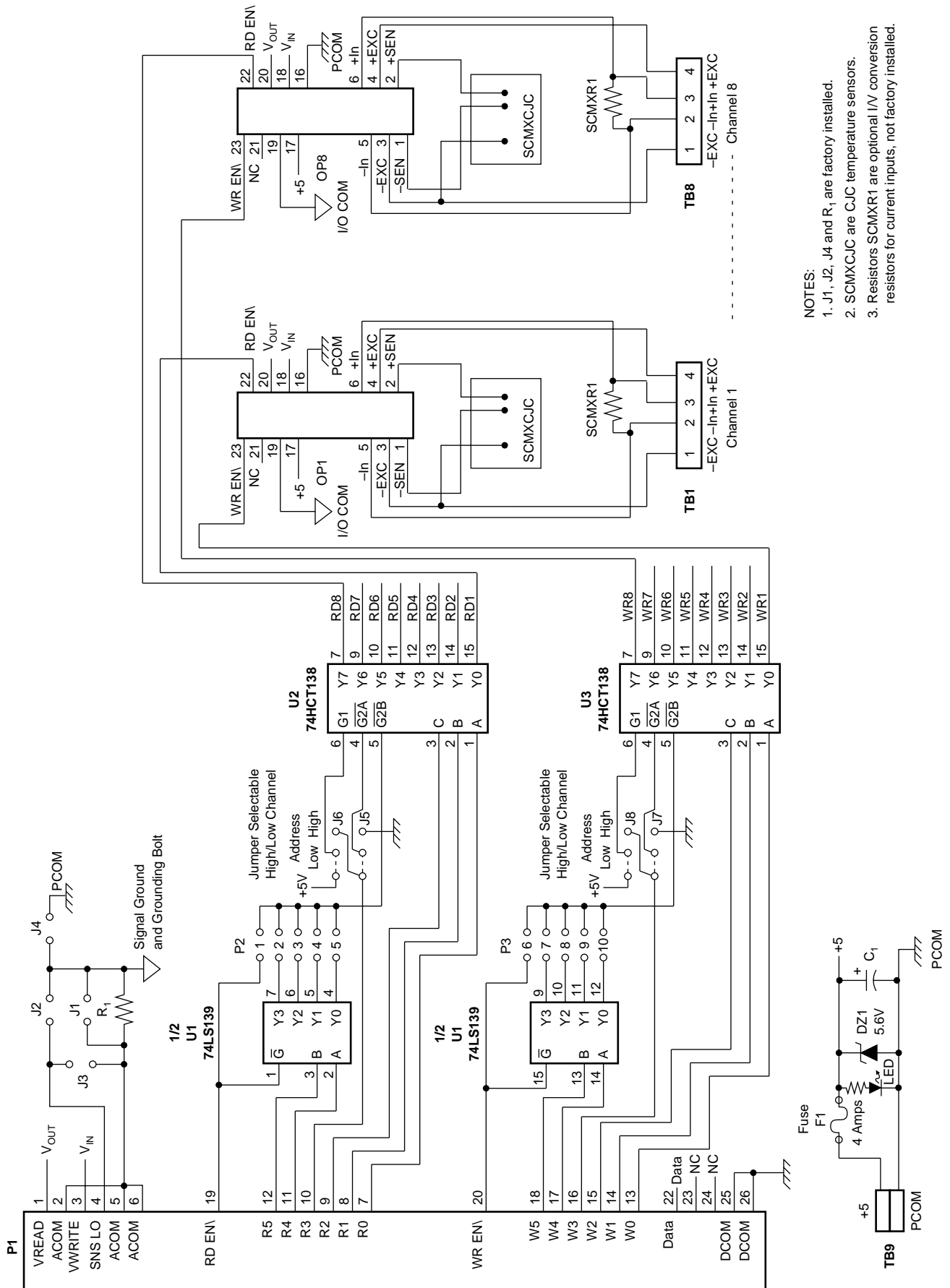

- NOTES:
1. J1, J2, J4 and R<sub>1</sub> are factory installed.
  2. SCMXCJC are CJC temperature sensors.
  3. Resistors SCMXR1 are optional I/V conversion resistors for current inputs, not factory installed.

FIGURE 15. SCMPB06 Schematic.



# SCMPB07 8-POSITION BACKPANEL, HIGH DENSITY

## DESCRIPTION

The SCMPB07 8-channel high-density backpanel can accept any of the SCM5B analog modules in any mixture. Its overall width is 5.5 inches (139.7mm) versus 10 inches (254mm) for the SCMPB05 and SCMPB06 8-channel backpanels. Separate analog signal paths are provided for each channel. Each channel provides four high-density screw terminals for field connections and two high-density screw terminals for host system connection. It also provides a jumper on each channel to optionally connect or isolate each module's I/O common from other channel's I/O common and/or power common. (Figure 16.)

See Figure 11 on page 86 for schematic.

## SPECIFICATIONS

Operating Temperature:	-40°C to +85°C 95% relative humidity, non-condensing
Interface Connector: Field System	High Density Screw Clamp, 14 AWG Max High Density Screw Clamp, 14 AWG Max

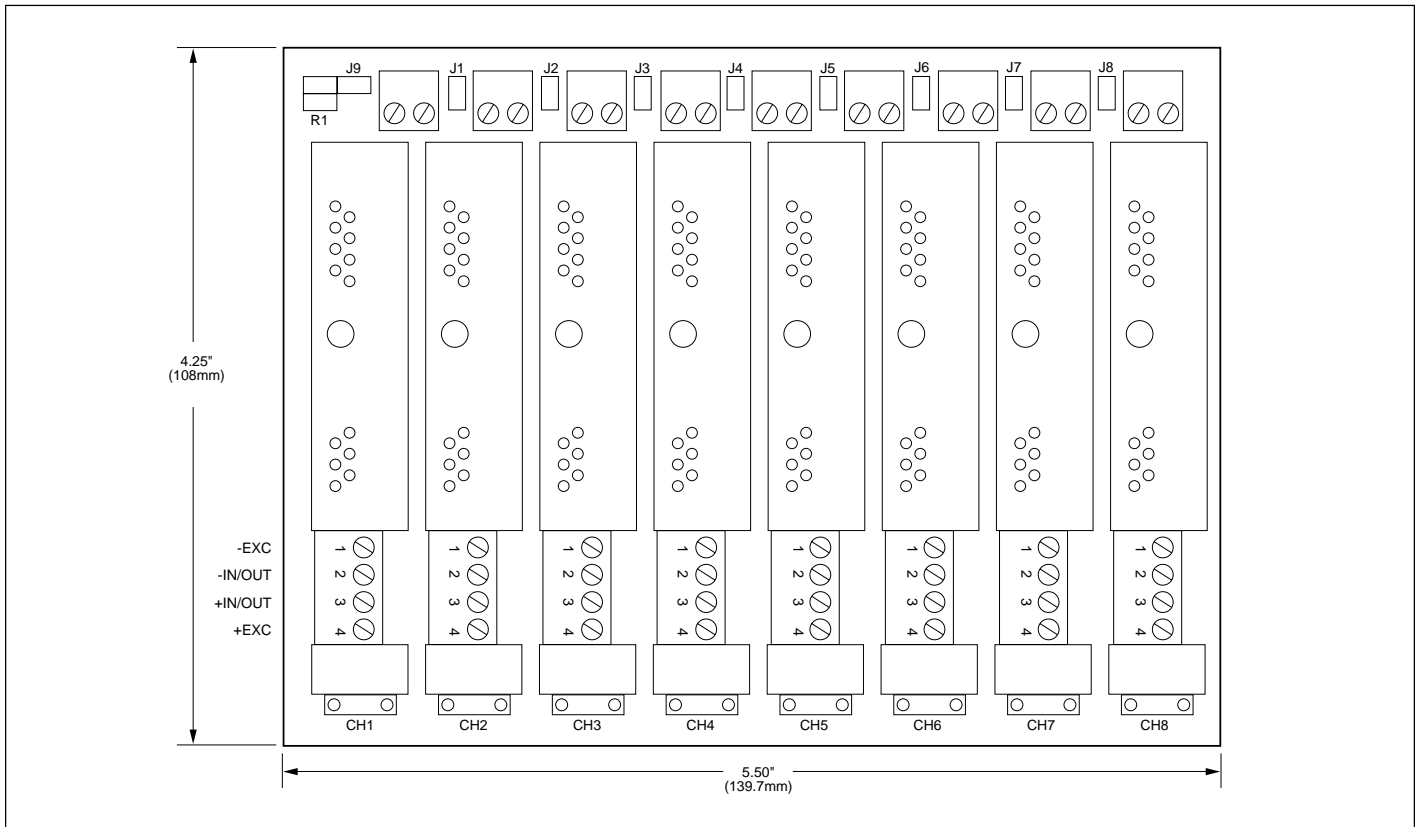

FIGURE 16. SCMPB07 Analog I/O Backpanel.

## ORDERING INFORMATION

Part Number	Description
SCMPB07	Standard 8-channel backpanel. No mounting hardware included.
SCMPB07-1	SCMPB07 without cold junction compensation circuits. Use when cost savings is desired and thermocouple input modules SCM5B37 and SCMPB47 will not be used.
SCMPB07-2	SCMPB07 with DIN RAIL mounting hardware. Shipped fully assembled. Accepts 8 SCM5Bxx-xx modules.
SCMPB07-3	SCMPB07-1 with DIN RAIL mounting option. See SCMPB07 and SCMPB07-2 for details.

SCM5B



# SCMXCA004-XX, SCMXCA005 INTERFACE CABLES

## DESCRIPTION

SCMXCA004-XX

System interface cable for the SCMPB01/02/05/06 backpanels. This is a 26 conductor ribbon cable with a mass-terminated socket connector installed on each end. It can be ordered in any length; -xx denotes required length in meters (Figure 19).

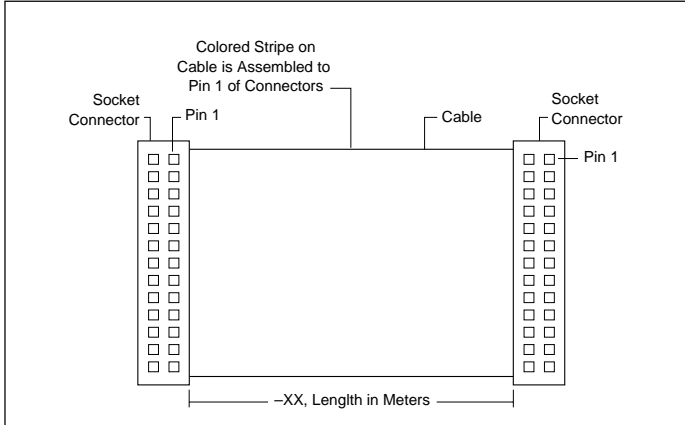

FIGURE 19. SCMXCA004-XX System Interface Cable.

SCMXCA005

Daisy-chain cable for the SCMPB02/06 backpanels (Figure 20). Provides interconnection between a maximum of four SCMPB02 and eight SCMPB06 backpanels.

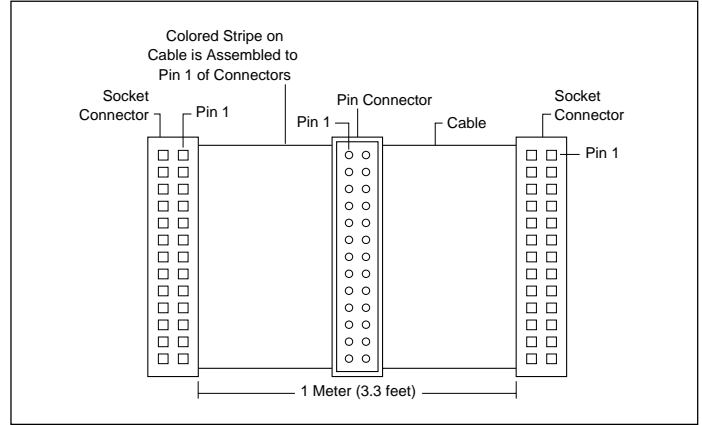

FIGURE 20. SCMXCA005 Daisy-Chain Cable.

# SCMXRK-002 19 INCH METAL MOUNTING RACK

## DESCRIPTION

The SCMXRK-002 is a 19-inch metal rack for mounting the SCMPB01/02/05/06 backpanels. It also provides capability to mount the SCMXPRT-001, SCMXPRE-001, SCMXPRT-003 or SCMXPRE-003 power supplies, and the SCMXIF interface board (See Figure 21 for dimensions).

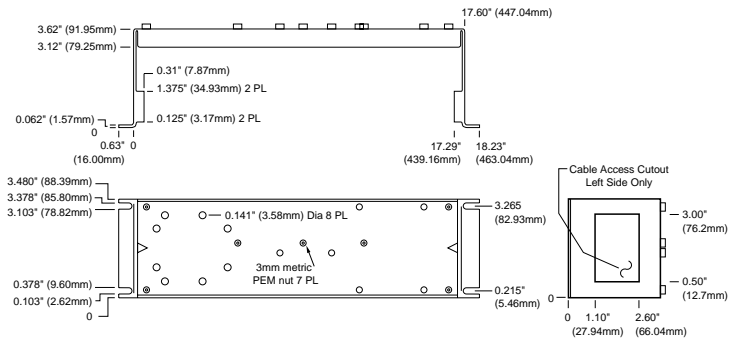

FIGURE 21. SCMXRK-002 Analog Rack Dimensions.

# SCMXIF UNIVERSAL INTERFACE BOARD

## DESCRIPTION

The SCMXIF is a universal interface board which converts a 26-pin ribbon cable input to 26 screw terminals for discrete wire. It can be mounted on the back of the SCMXRK-002 mounting rack (SCMXIF) or on a DIN rail (SCMXIF-DIN). Required mounting hardware is included. Use SCMXCA004-XX cable (See Figure 22 for dimensions).

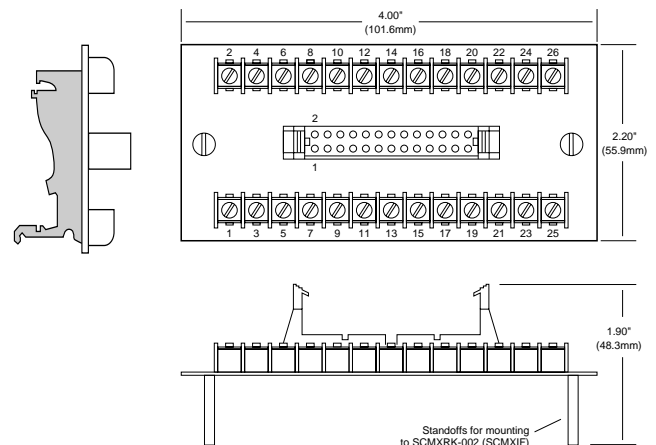

FIGURE 22. SCMXIF Universal Interface Board Dimensions.

Call 800-444-7644  
For Information and Assistance

**DATAFORTH**<sup>®</sup>  
A Burr-Brown Company



# SCMXCJC ENCAPSULATED COLD JUNCTION COMPENSATION

## DESCRIPTION

The SCMXCJC is the identical circuit used on the SCMPB01/02/03/04/05/06 backpanels except it is packaged as a component for use in customer designed mounting boards (Figure 23). When interfaced to an SCM5B37 or 47 module the transfer function of the voltage across the +SEN and -SEN pins is  $V_{CJC} = 0.510 - 0.0025(T - 25)V$ .

## SPECIFICATIONS

Accuracy	+25°C	±0.25°C
	+5°C to +45°C	±0.5°C
	-40°C to +85°C	±1.25°C

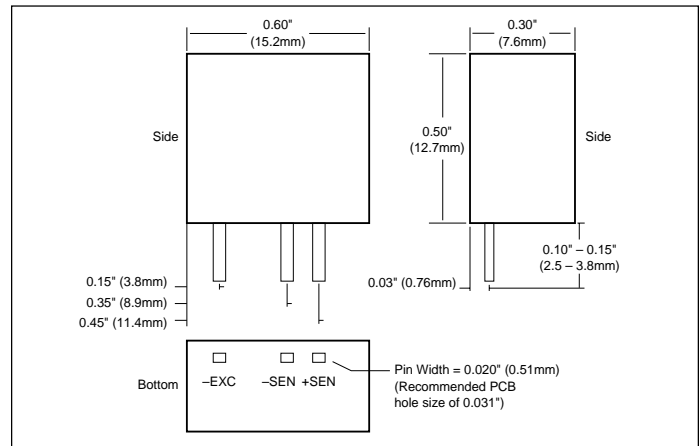

FIGURE 23. SCMXCJC Physical Dimensions And Pin Layout.

## SCM5BDS DEAD SHORT

## DESCRIPTION

This accessory is a pass through module used to establish a direct connection between the field-side and the system-side. It has unity gain and no

isolation. Internally, the +IN pin (pin 6) is connected to the VOUT pin (pin 20) and the -IN pin (pin 5) is connected to the I/O COM pin (pin 19).

## SCMXFS-003 FUSE

## DESCRIPTION

Package of 10, 4 amp fuses for use on the SCMPB01 or SCMPB02 backpanel. This is a series fuse in the five volt power line. It provides protection against

inadvertent reverse connection of five volt power.

## SCMXJP-003 JUMPER STRAP

## DESCRIPTION

Package of 10 jumpers for connecting adjacent input/output modules on the SCMPB01 backpanel. This connection is made if it is desired to direct the

output of any input module to the input of an adjacent output module. The jumpers can also be used for configuring I/O addresses on the SCMPB02 backpanel.



# SCMXR1 CURRENT CONVERSION RESISTOR

## DESCRIPTION

A precision 20Ω, 0.1%, 10ppm/°C resistor used with the SCM5B32 current input module or SCM5B42 two-wire transmitter interface module (Figure 24). Sockets are provided on the SCMPB01/02/03/04/05/06/07 and SCMXEV backpanels to allow installation of this resistor. One SCMXR1 is shipped with each SCM5B32 or SCM5B42 module.

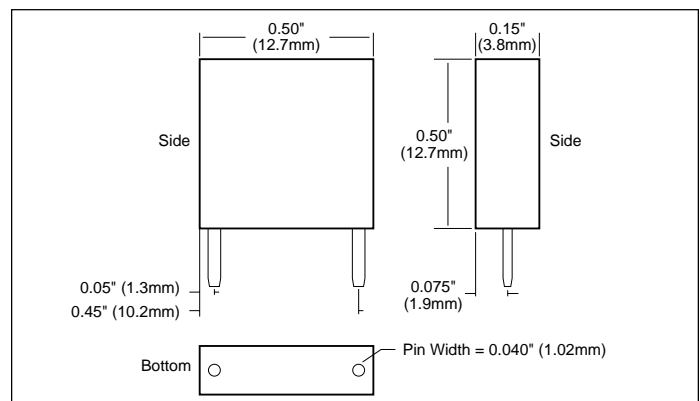

FIGURE 24. SCMXR1 Physical Dimensions.



Call 800-444-7644  
For Information and Assistance

# SCM5B-PROTO: Breadboard Kit

## DESCRIPTION

The SCM5B-PROTO breadboard kit was designed to allow users to incorporate their own module functions using an SCM5B format. The kit includes a

pc board designed for breadboard circuits, a module case, header and mounting screw. Contact the factory for additional information.

## SCMXRAIL1-XX, SCMRAIL2-XX, SCMXRAIL3-XX DIN RAIL

## DESCRIPTION

Three styles of DIN RAIL are available, specify length when ordering.

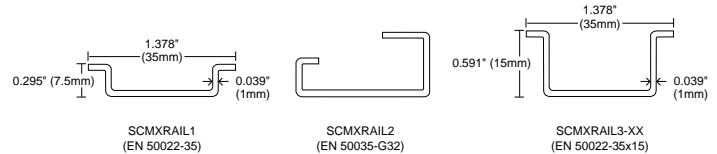

FIGURE 25. DIN Rail Styles.



## SCMXPRT-001, SCMXPRT-001 POWER SUPPLIES

## DESCRIPTION

The SCMXPRT-001 and SCMXPRT-001 encapsulated power supplies are available in 120VAC or 220VAC input voltage ranges and provide 5VDC outputs suitable for all SCM5B modules. They are designed to mount on the

SCMXPRT-001 metal rack. The supplies are UL-recognized and CSA certified. Their compact size and low weight are ideal for high-density applications (see Figure 26.).

## SPECIFICATIONS

	SCMXPRT-001	SCMXPRT-001
Input Voltage Range	105-125VAC	200-240VAC
Output Voltage	5VDC	5VDC
Output Current, +50°C (derate 2.5%/°C above +50°C)	1A	1A
Operating Temp	-25°C to +71°C	-25°C to +71°C
Dielectric Withstand Voltage (Input to Ground)	2500VRMS	2500VRMS
Line Regulation	±0.05%	±0.05%
Load Regulation	±0.15%	±0.15%
Output Ripple, max	2mVRMS	2mVRMS
Overvoltage Protection, nominal	6.2V	6.2V
Weight	1.25 lbs (567 grams)	1.25 lbs (567 grams)

Supplies are UL recognized, File No. E65890, and CSA certified, File No. LR59996.

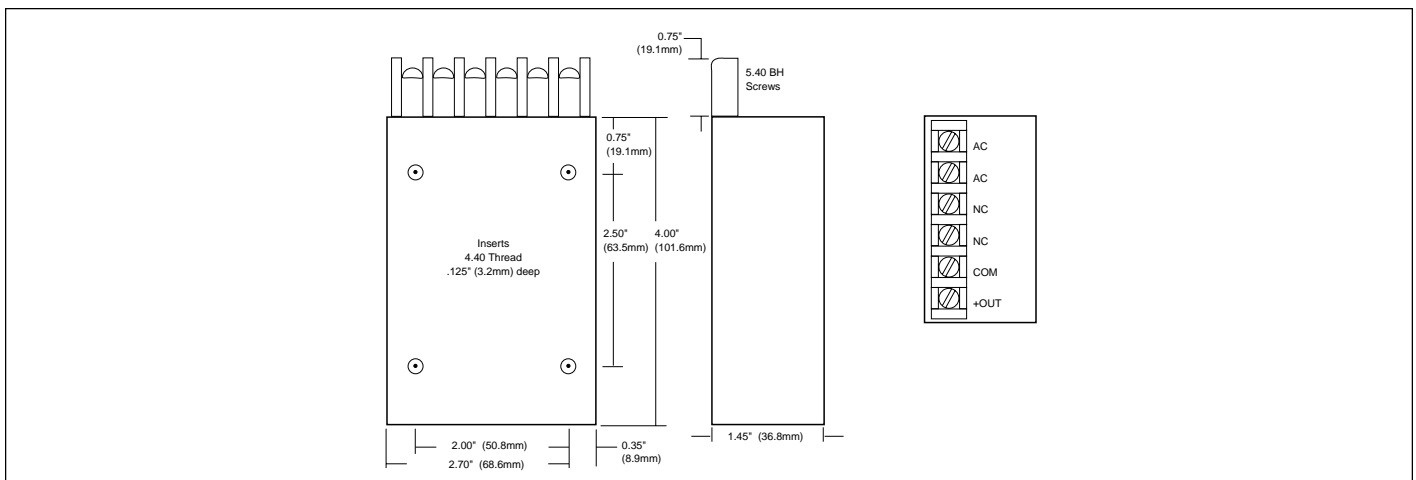

FIGURE 26. SCMXPRT-001/E-001 Physical Dimensions.

Call 800-444-7644  
For Information and Assistance





# SCMXPRT-003, SCMXPRE-003 POWER SUPPLIES

## DESCRIPTION

The SCMXPRT/E-003 Linear Power Supplies are available in 120VAC or 220VAC input. They have sufficient output current capacity to supply any combination of SCM5B modules. The SCMXRK-002 metal rack provides mounting capability for the SCMXPRT/E-003 power supplies (See Figure 27).

## SPECIFICATIONS

	SCMXPRT-003	SCMXPRE-003
Input Voltage Range	104-132VAC	207-265VAC
Output Voltage	5VDC $\pm 1\%$	5VDC $\pm 1\%$
Output Current (at +70°C)	3A	3A
Output Current (at +50°C)	6A	6A
Operating Temp	0 to +70°C	0 to +70°C
Dielectric Withstand Voltage (input to ground)	3750VAC	3750VAC
Line Regulation (10% line change)	$\pm 0.05\%$	$\pm 0.05\%$
Load Regulation (50% load change)	$\pm 0.05\%$	$\pm 0.05\%$
Output Ripple (max)	5 mV <sub>p-p</sub>	5 mV <sub>p-p</sub>
Overvoltage Protection (factory set)	6.2 V $\pm 0.4V$	6.2 V $\pm 0.4V$

Both supplies are tested and certified by TUV to VDE 0806 and IEC 380. They are UL Recognized (File Number E55974) and CSA Certified (CSA File Number LR38879).

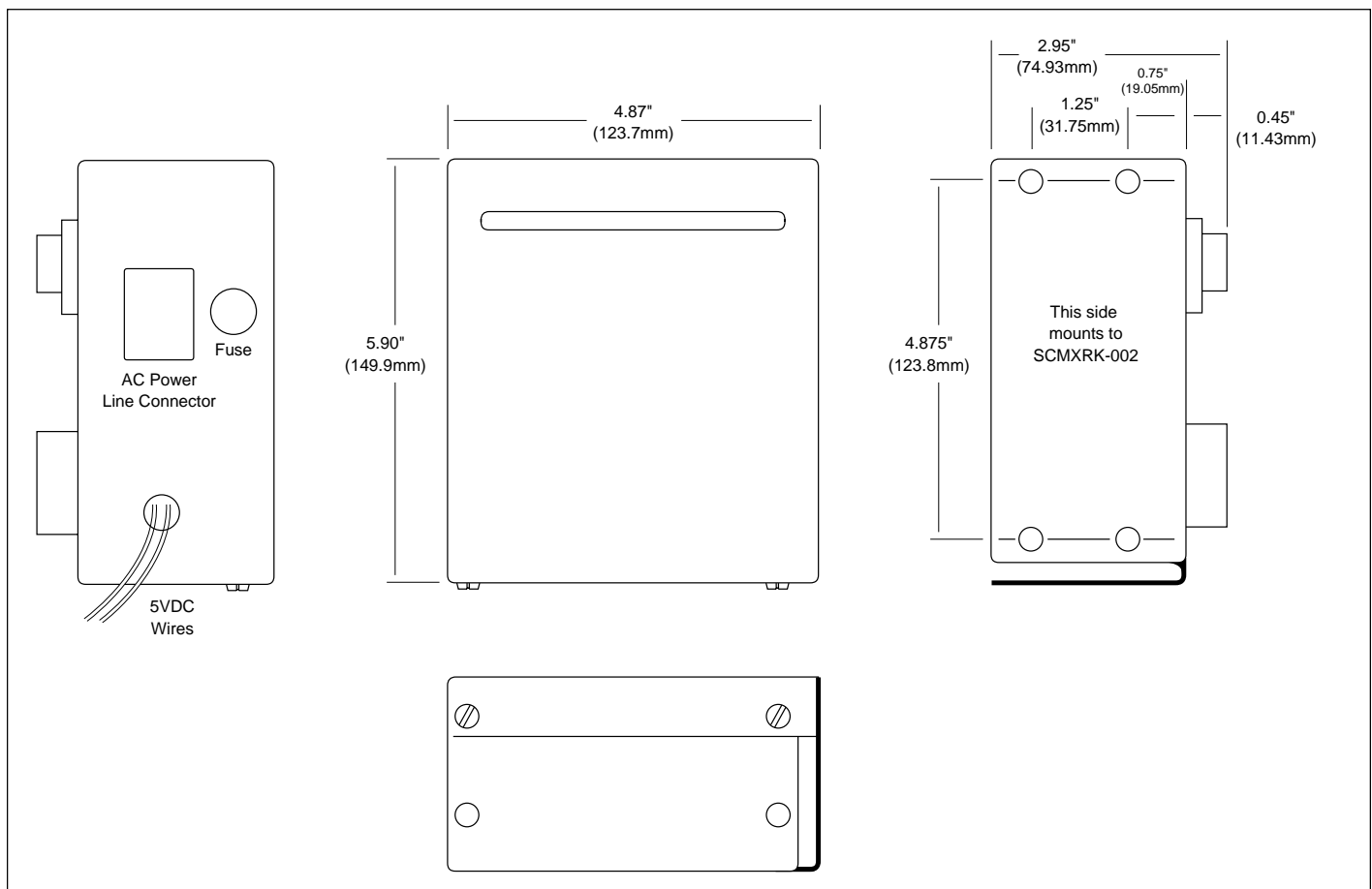

FIGURE 27. SCMXPRT-003/E-003 Physical Dimensions.