

# SCM9B-5000 Series



## Four Channel Sensor-to-Computer Modules

### Description

The SCM9B-5000 Four Channel Sensor-to-Computer Modules are a family of complete solutions designed for data acquisition systems based on personal computers and other processor-based equipment with standard serial I/O ports. The modules convert four analog input signals to engineering units and transmit in ASCII format to any host with standard RS-485 or RS-232C ports. These modules can measure temperature, voltage, and current. The modules provide direct connection to a wide variety of sensors and perform all signal conditioning, scaling, linearization, and conversion to engineering units.

Each channel of the SCM9B-5000 Series can be independently programmed by the user for zero, span, and filter, to scale linear input signals such as millivolts and milliamps to desired engineering units such as pounds or percent of full scale.

The SCM9B-5000 modules are easy to use. With these modules, anyone familiar with a personal computer can construct a data acquisition system. This modular approach to data acquisition is extremely flexible, easy to use, and cost effective. Data is acquired on a per channel basis so you only buy as many channels as you need. The modules can be mixed and matched to fit the application. They can be placed remote from the host and from each other.

The modules contain no pots or switches to be set. Features such as address, baud rate, parity, echo, and scaling are selectable using simple commands over the communications port—without requiring access to the module. The selections are stored in nonvolatile EEPROM which maintains data even after power is removed.

The 5000 series is completely hardware and software-compatible with the 1000, 2000, 3000 and 4000 series and may be mixed in any combination.

All modules are supplied with removable screw-terminal connectors and captive mounting hardware. The connectors allow system expansion, reconfiguration or repair without disturbing field wiring.

Although software is not required, utility software (S1000) is available on IBM-compatible diskette to make the 5000 easier to learn and use.

### ► Features

- Four Analog Input Channels
- Complete Sensor to RS-485 or RS-232 Interface
- ASCII Format Command/Response Protocol
- 500Vrms Analog Input Isolation
- 15 Bit Measurement Resolution
- Continuous Self-calibration; No Adjustments of Any Kind
- Programmable Digital Filter
- Requires +10V to +30VDC Unregulated Supply
- Transient Suppression on RS-485 Communications Lines
- Screw Terminal Plug Connectors Supplied
- Mix and Match with Single-Channel Units on Same Backpanel
- CE Marked

### ► Applications

- Process Monitoring and Control
- Remote Data Logging to any Host Computer
- Product Testing
- Direct Connection to Modems

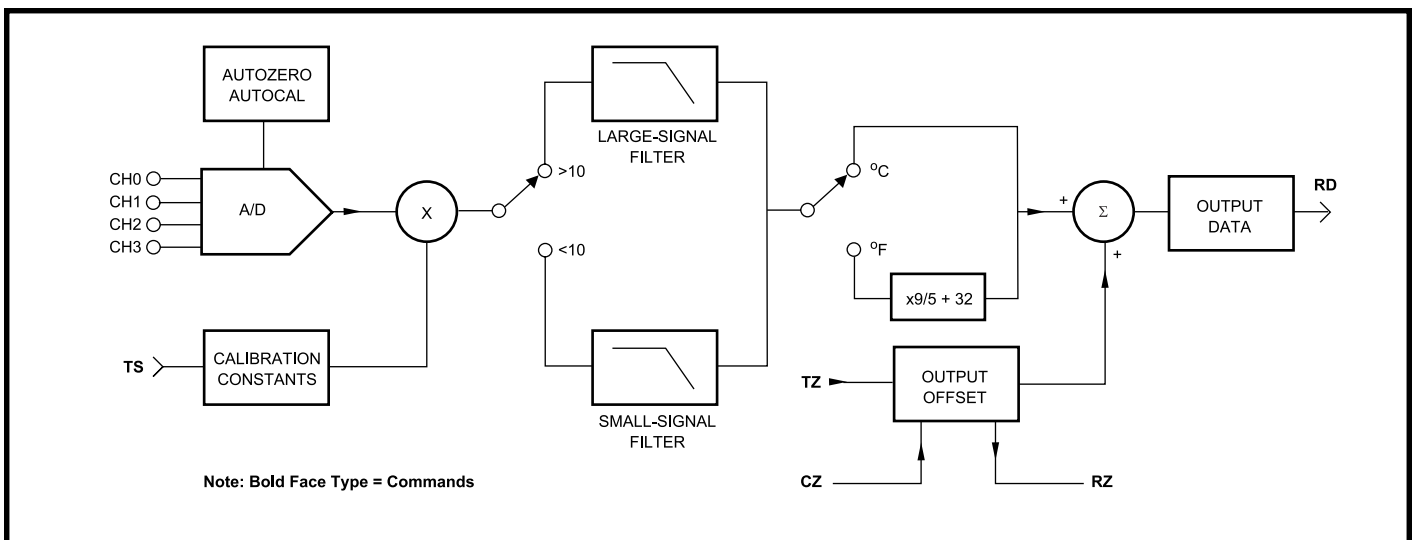

Figure 1: SCM9B-5000 Block Diagram

**Specifications** Typical at 25°C and nominal power supply unless otherwise noted

**Analog**

- Four channel analog input.
- Maximum CMV, input to output at 60Hz: 500Vrms.
- Leakage I, input to output at 115Vrms, 60Hz: <math>2\mu\text{Arms}</math>.
- 15 bit measurement resolution.
- 8 conversions per second.
- Common mode rejection: 100dB at 50/60Hz.
- Autozero & autocalibration—no adjustment pots.

**Digital**

- 8-bit CMOS microcomputer.
- Digital scaling, linearization and calibration.
- Nonvolatile memory eliminates pots and switches.
- Small and large signal digital filtering with user selectable time constants.

**Communications**

- Communications in ASCII via RS-232C, RS-485 ports.
- Selectable baud rates: 300, 600, 1200, 2400, 4800, 9600, 19200, 38400, 57600, 115200.
- NRZ asynchronous data format; 1 start bit, 7 data bits, 1 parity bit and 1 stop bit.
- Parity: odd, even, none.
- User selectable channel address.
- ASCII format command/response protocol.
- Up to 3721 multidrop modules per host serial port.
- Communications distance up to 4,000 feet (RS-485).
- Transient suppression on RS-485 communications lines.
- Communications error checking via checksum.
- Scan up to 250 channels per second.
- All communications setups stored in EEPROM.

**Power**

- Requirements: Unregulated +10V to +30VDC, 0.75W max.
- Protected against power supply reversals.

**Environmental**

- Temperature Range: Operating -25°C to +70°C.  
Storage -25°C to +85°C.
- Relative Humidity: 0 to 95% noncondensing.

**Mechanical**

- Dimensions: See Dimension drawing.
- Case: ABS with captive mounting hardware.
- Connectors: Screw terminal barrier plug (supplied).  
Replace with Phoenix MSTB 1.5/10ST 5.08 or equivalent.

**5100 Voltage Inputs**

- Voltages:  $\pm 100\text{mV}$ ,  $\pm 1\text{V}$ ,  $\pm 5\text{V}$ ,  $\pm 10\text{V}$ ,  $\pm 100\text{VDC}$ .
- Resolution: 0.01% of FS (4 digits).
- Accuracy:  $\pm 0.02\%$  of FS max.
- Zero drift:  $\pm 1$  count max (autozero).
- Span tempco:  $\pm 50\text{ppm}/^\circ\text{C}$  max.
- Input burnout protection to 250VAC.
- Input impedance:  $\leq \pm 1\text{V}$  input =  $100\text{M}\Omega$  min.  
 $\geq \pm 5\text{V}$  input =  $1\text{M}\Omega$  min.

**5200 Current Input**

- Current: 4-20mADC.
- Resolution: 0.04% of FS.
- Accuracy: 0.04% of FS.
- Zero drift:  $\pm 1$  count max (autozero).
- Span tempco:  $\pm 50\text{ppm}/^\circ\text{C}$  max.
- Voltage drop: 1.0V max.

**5300 Thermocouple Inputs**

- Thermocouple types: J, K, T, E (factory set).
- Ranges: J = -200°C to +760°C T = -200°C to +400°C  
K = -150°C to +1250°C E = -100°C to +1000°C
- Resolution:  $\pm 1^\circ$ .
- Overall Accuracy (error from all sources) from 0 to +40°C ambient:  $\pm 1.0^\circ\text{C}$ .
- Input impedance:  $100\text{M}\Omega$  min.
- Lead resistance effect:  $<20\mu\text{V}$  per  $350\Omega$ .
- Open thermocouple and overrange indication.
- Input burnout protection to 250VAC.
- User selectable  $^\circ\text{C}$  or  $^\circ\text{F}$ .
- Automatic cold junction compensation and linearization.

**5450 Thermistor Inputs**

- Thermistor types: 2252 $\Omega$  at 25°C.
- Range: -0°C to +100°C.
- Resolution: 0.01°C or F.
- Accuracy:  $\pm 0.1^\circ\text{C}$ .
- Input protection to 30VDC.
- User selectable  $^\circ\text{C}$  or  $^\circ\text{F}$ .

Specifications are subject to change without notice.

**Ordering Information**
**Voltage Input**

| Model      | Description                             |
|------------|---|
| SCM9B-5111 | $\pm 100\text{mV}$ Input/RS-232C Output |
| SCM9B-5112 | $\pm 100\text{mV}$ Input/RS-485 Output  |
| SCM9B-5121 | $\pm 1\text{V}$ Input/RS-232C Output    |
| SCM9B-5122 | $\pm 1\text{V}$ Input/RS-485 Output     |
| SCM9B-5131 | $\pm 5\text{V}$ Input/RS-232C Output    |
| SCM9B-5132 | $\pm 5\text{V}$ Input/RS-485 Output     |
| SCM9B-5141 | $\pm 10\text{V}$ Input/RS-232C Output   |
| SCM9B-5142 | $\pm 10\text{V}$ Input/RS-485 Output    |
| SCM9B-5151 | $\pm 100\text{V}$ Input/RS-232C Output  |
| SCM9B-5152 | $\pm 100\text{V}$ Input/RS-485 Output   |

**Current Inputs**

| Model      | Description                 |
|------------|-----------------------------|
| SCM9B-5251 | 4-20mA Input/RS-232C Output |
| SCM9B-5252 | 4-20mA Input/RS-485 Output  |

**Thermocouple Inputs**

| Model      | Description                         |
|------------|-------------------------------------|
| SCM9B-5311 | J Thermocouple Input/RS-232C Output |
| SCM9B-5312 | J Thermocouple Input/RS-485 Output  |
| SCM9B-5321 | K Thermocouple Input/RS-232C Output |
| SCM9B-5322 | K Thermocouple Input/RS-485 Output  |
| SCM9B-5331 | T Thermocouple Input/RS-232C Output |
| SCM9B-5332 | T Thermocouple Input/RS-485 Output  |
| SCM9B-5341 | E Thermocouple Input/RS-232C Output |
| SCM9B-5342 | E Thermocouple Input/RS-485 Output  |

**Thermistor Inputs**

| Model      | Description                                   |
|------------|---|
| SCM9B-5451 | 2252 $\Omega$ Thermistor Input/RS-232C Output |
| SCM9B-5452 | 2252 $\Omega$ Thermistor Input/RS-485 Output  |